

# The Thurston Collection of Laboratory Artifacts at Cornell University

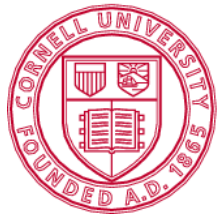

Cornell University  
College of Engineering



Sibley School of Mechanical  
and Aerospace Engineering

An ASME Heritage Collection



## **Mechanical Engineering Heritage Collection Robert H. Thurston Collection - Cornell University**

### **Early Engineering Laboratory Devices and Testing Machines**

The devices in this collection, used at Cornell between 1885 and 1905, exemplify Robert Henry Thurston's vision of the central role of the engineering laboratory in training mechanical engineers.

Building on his work at Stevens Institute of Technology, Thurston fully implemented his vision at Cornell's Sibley College of Mechanical Engineering and Mechanic Arts, which under his leadership became the largest and most influential mechanical engineering program in the U.S. Thurston's emphasis on engineering laboratories achieved national and international recognition as the key to moving engineering training from shop to university.



American Society of Mechanical Engineers 2019

**College of Engineering, Cornell University, Ithaca, New York**

Founded in 1865

Lance Collins, Ph.D., Professor and Dean

**Sibley School of Mechanical and Aerospace Engineering**

Mark Campbell, Ph.D., Professor and Director

Cover illustrations: Top: Large gear from the Thurston torsion testing machine, 1880;  
Middle: Thurston's lubrication testing machine c.1873.  
Photos; FC Moon

## Robert Henry Thurston Collection of 19<sup>th</sup> Century Engineering Laboratory Equipment

The Thurston Collection consists of laboratory testing machines and pedagogical tools used to instruct mechanical engineering students at Cornell's Sibley School of Mechanical Engineering during the late 19<sup>th</sup> century (see list of artifacts on p. 11). Its historical importance is due to its association with Robert H. Thurston. Thurston was the leading proponent of the engineering testing laboratory as a means of giving mechanical engineering students training that would be, simultaneously practical and scientific. It was at Cornell that Thurston's vision of the engineering laboratory as a centerpiece of mechanical engineering training reached maturity and attained broad national and international recognition.

In addition, the artifacts include important testing machines that Thurston designed, including the first device to automatically measure both stress and strain without electronics (1871, patented 1874, 1880). This machine was used in Thurston's pioneering work on work-hardening metals. Another device in the collection is an instrument Thurston invented to measure the lubricating properties of machine oils, one of the first of its type.

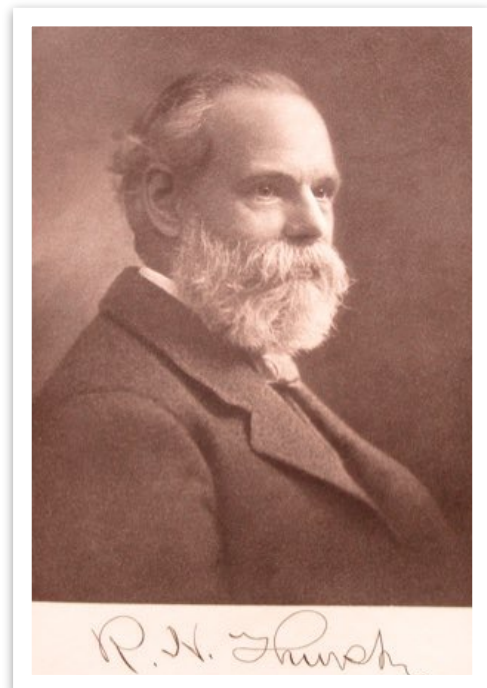

Robert H Thurston was the first president of ASME and served for two terms in the years 1880-1882. His experience in the Navy and teaching at the Naval Academy at Annapolis Maryland, taught him the value of designing engineering systems with knowledge of material properties derived from scientific principles. In his early years at Stevens Institute of Technology and later at Cornell University he developed an engineering curriculum that combined science, mathematics, design, shop experience, and laboratory testing of both materials and larger engineering systems.

≡ **LABORATORIES** ≡

) OF THE (

# Sibley College of Mechanical Engineering

✦ CORNELL UNIVERSITY. ✦

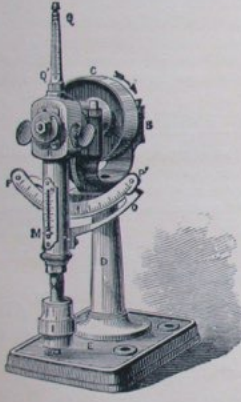

**F**ACILITIES for all kinds of Engineering Investigation and Scientific Research. Great variety of testing machines for materials — 15,000, 20,000, 50,000, 100,000, 200,000 and 300,000 pounds capacity; oil testing machines; dynamometers; and every kind of experimental apparatus, including “experimental” steam engines up to 200 H. P.

*In connection with the work in Courses of Instruction leading to Degrees in Mechanical Engineering and Electrical Engineering, a limited amount of commercial work in tests of the Materials of Engineering and the trials of Engines, Boilers, Dynamos, etc., can be done at fixed charges, where the results may be used for the benefit of the class. . . . .*

79

R. H. THURSTON, DIRECTOR.

For particulars and prices, address

Advertisement by Professor Thurston of the commercial facilities for testing materials in the Sibley Testing Laboratories

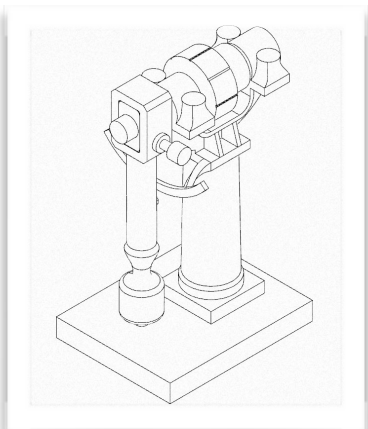
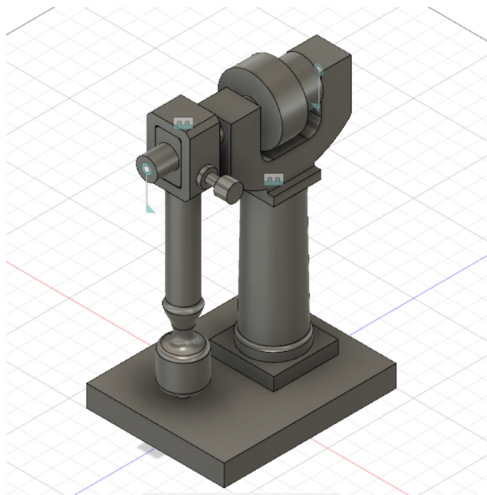

Modern CAD drawings of the Thurston Lubrication testing machine [Stanley Lok BSME '19]

## Robert H Thurston [1839-1903] Engineer, Scientist, Educator, Statesman

Why honor Robert Thurston more than a century after his death? He was one of the best known engineers in the United States in the late 19th century. Yet when William Durant wrote a biography of Thurston in 1929, he observed that young engineers barely knew who Thurston was.

Robert Henry Thurston's career was inevitably tied to the development of steam power. He was born in Providence, Rhode Island, in 1839. In 1830, Thurston's father Robert Lawton Thurston had become a partner with John Babcock in a company that built steam engines especially suited for marine applications. These included a version of the Noble T. Greene steam engine, a rival to the famous Corliss engines.

Greene steam engine model built by R.T. Thurston before he was a student at Brown University



In 1855, a year before enrolling at Brown University, the young Thurston built an operating model of a Greene engine using the facilities of his father's shops. That model is in the Cornell Collection.

After graduating with a "Certificate" in engineering from Brown in 1859, Thurston began a traditional engineering apprenticeship in his father's company and soon advanced to more responsible positions. That company had Navy contracts, so it is not surprising that young Robert Henry Thurston enlisted in the Navy, then beginning its steam power era, when the Civil War broke out in 1861. He served through the war as an engineering officer.

After the war ended, Thurston was transferred to the Naval Academy at Annapolis, where he served on the faculty and began testing lubricating oils and steam engines and publishing articles on a variety of engineering subjects. In 1871, he accepted a position as professor of mechanical engineering at Stevens Institute of Technology in Hoboken, New Jersey, one of the nation's pioneering academic mechanical engineering programs. At Stevens, Thurston began implementing his ideas for a more science and mathematics-based mechanical engineering

curriculum, including the use of engineering testing laboratories to combine hands-on work with theory. At the same time, he wrote and published a number of widely used books on the history and science of steam engines.



Model of Watt steam engine

While on the faculty at Stevens, Thurston was appointed to a national board to study steam boiler explosions. These accidents killed several hundred people a year in the United States. His work on the strength of the materials used to construct steam boilers prompted his invention of a materials testing machine. Work with this machine led Thurston to the discovery of work hardening (discussed later). Thurston's investigations on boiler safety were a forerunner of the *ASME Piping and Pressure Vessel Code* that has saved thousands of lives by reducing or preventing boiler explosions. His work

Right: Steam engine pressure-displacement indicator used to test engine power

with steam boiler materials eventually led to the publication of a three-volume, *Materials of Engineering* in 1883.

Thurston's accomplishments soon attracted national attention. In 1880, John Sweet, formerly a professor at Cornell, called for a meeting in New York City to create a professional organization of engineers working in the fields of steam-powered transportation and manufacturing, feeling that existing engineering organizations did not cover those fields sufficiently. At age forty-one, Thurston, of Stevens Institute of Technology, was elected the first president of the new American Society of Mechanical Engineers.

In 1885 Thurston left Stevens to become head of Cornell University's Sibley College. There he was given both financial and institutional backing to transform that struggling program into the premier academic mechanical engineering program in the country. Thurston increased entrance requirements, hired quality faculty, cultivated close contacts with engineers working in industry, extensively publicized Sibley's program, promoted lengthy field trips to operating industrial plants, and regularly invited prominent engineers to campus. Many of these actions were de-



signed to harmonize academic training with engineering practice.

Given wide authority at Cornell, Thurston was able to fully implement his vision of mechanical engineering as a scientifically grounded profession where basic training initially came academically rather than in a machine shop. Besides increased focus on science and mathematics, one of the linchpins of the curriculum he developed at the Sibley College was the *engineering testing laboratory* where both materials and machines were tested, based on the sciences of mechanics and thermodynamics.

Thurston was among the earliest university leaders to recognize the importance of the emerging field of electric power, initiating one of the nation's first academic electrical power programs in Sibley College; he added courses on engineering economics as well.

To disseminate his ideas on how engineers should be trained, Thurston wrote numerous non-technical articles on engineering education, some of which appeared in Cornell's *Sibley Journal of Engineering* [1885-1919], which he edited until his death. In addition to all of Thurston's books, the Cornell Library has the complete collection of the *Sibley Journal of Engineering*. Thurston published an extensive article in the *Transactions of the American Society of Mechanical Engineers* in 1893 that provided an

elaborate description of the educational program he initiated at Cornell.

When Thurston arrived at Cornell, the Sibley School had about 60 students. When he died in 1903, Cornell's Sibley School had over forty faculty members in seven departments teaching nearly a thousand students. It was the **largest and best known mechanical engineering program in the US.**

Thurston began his career in the age of steam power and steam transportation and finished his career in the age of electric power and the gasoline engine. He died a few weeks before his friend Samuel Langley and Cornell graduate Charles Manly would fail in their attempt to fly a heavier than air machine, and the Wright Brothers would succeed in that endeavor. A decade earlier, Thurston had encouraged another friend Octave Chanute, a Sibley Lecturer, to organize an international meeting on flying machines in 1893.

*Science* magazine in its November 1903 obituary of Thurston wrote, "There can be no doubt ... that it [the scientific and engineering work of Thurston] was of great benefit to mankind, for he made engineers better scientists, promoted engineering education, and helped to put engineering upon a higher professional plane...."

Thurston's influence on engineering education was widespread. He wrote numerous articles on engineering science and its role in engineering education, one of which the great German engineer Franz Reuleaux of the Berlin Polytechnic Institute had translated into German. European engineers traveling in America often stopped by Cornell to see Thurston's program and its engineering laboratories first hand.

### Thurston's Research in Engineering Science

Thurston is today best known for his role in transforming mechanical engineering from a shop-based, practical profession into one based on scientific design and academic training. In his own time, however, he was also widely known for his contributions to engineering science.

His work in thermodynamics was widely known because he wrote both popular and technical books on steam power. His 1878 *History of the Growth of the Steam Engine*, for example, had gone through four editions by his death. He also translated Carnot's pioneering 1824 treatise – the first theoretical study of heat engines -- from French to English in 1890.

Thurston also made important contributions to the mechanics of materials. As noted previously, in 1884 he published a three-volume book on engineering materials. In this book he not only summarized

the properties of materials but included chapters on how to establish those properties using scientific laboratory measurements.

#### ***Work Hardening of Metals***

One of Thurston's major discoveries was work hardening [strain-hardening] of metals in 1873. Systematically testing the materials that went into boiler construction, he found that the **elastic limit of both steel and wrought iron were increased** when the metals were initially stressed beyond their elastic limits. This discovery had practical design implications in both civil and mechanical engineering work. One of the key testing machines he used in this work is illustrated below.

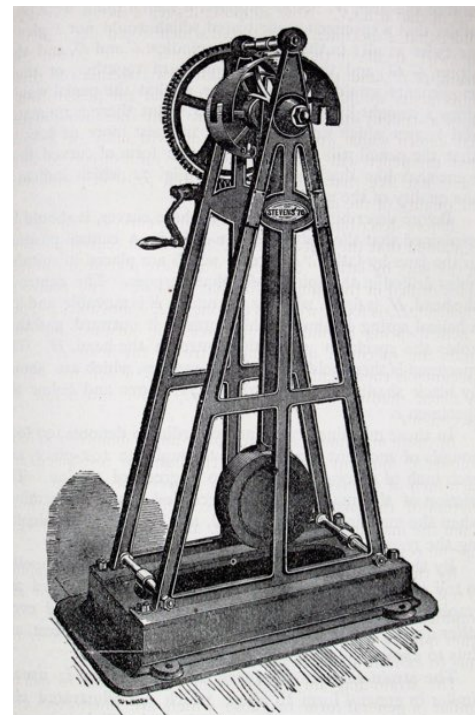

Thurston's Autographic Testing Machine as shown in his *Materials of Engineering* text.



[Thurston] “designed and developed an autographic torsion testing machine, measurements from which deeply influenced the thinking of the next forty years.” “This apparatus provided the prototype for the present day standardized automated materials testing devices.”

James F Bell in his 1973 work *The Experimental Foundations of Solid Mechanics*.

### ***Invention of a Lubrication Testing Machine***

In addition to developing equipment to scientifically test the materials properties important for the machine design, Thurston also developed equipment to study machine efficiency. One important, but often overlooked, component of machine operation is the loss of energy due to friction. In connection with consulting work for railroad companies, Thurston invented a machine to measure the viscous properties of lubricants that reduce friction. In an article in the *Journal of the Franklin Institute* and volume 3 of his *Materials of Engineering*, Thurston described the construction of his new machine and the mathematical and physical principles on which it worked. This machine is in the possession of Cornell today and is one of the artifacts in the Thurston Collection.

### ***National and International Statesman for Mechanical Engineering***

Thurston’s professional activities went beyond his roles as an engineering scientist and a renowned engineering educator. As already noted, he served as first president of the American Society of Mechanical Engineers (1880-1882). He also served as vice president of the American Association for the Advancement of Science (AAAS) and vice president of the American Institute of Mining Engineers. In addition to his service on the US board to test the materials used to construct steam boilers, he was the US Commissioner to the 1873 Vienna Exhibition or World’s Fair. He wrote seventeen letters for publication in *Scientific American* on the technical exhibits at the Exhibition. He also visited several European countries and reported on the progress of mechanical engineering education there. He made two other trips to Europe, in 1889 and 1894.

As Director of the Sibley College at Cornell he invited many famous engineers to lecture to the students. The Cornell Collection of Thurston’s personal papers in the Rare Manuscripts Division includes correspondence from famous engineers and capitalists at the time, such as, Thomas Edison, Andrew Carnegie, Samuel Langley, Cyrus McCormick, Alexander G. Bell, and Nikola Tesla.

## The Sibley School of Mechanical and Aerospace Engineering Today

In 1920, Cornell University merged the Sibley College and the College of Civil Engineering into a unified College of Engineering. At the same time the department of Electrical Engineering was made into an independent School. Sibley College became the Sibley School of Mechanical Engineering, later adding Aerospace Engineering and Theoretical and Applied Mechanics to its faculty.

Today the School has close to forty faculty and produces over 150 undergraduates a year. There is a substantial graduate research program ranging in topics from mechanics of fluids and solids, combustion, biomechanics, space satellites, robotics, control engineering, wind energy and nanotechnology.

One of the hallmarks of the modern Sibley School program in mechanical engineering follows in Robert Thurston's footsteps, in hosting the College of Engineering **Student Project Team Facility**. This is **hands-on experiential learning laboratory** in which students create machines to compete on a national level, including: SAE vehicles, underwater vehicles, wind power, robotics and controlled aircraft models. Over the past thirty years, student teams have won dozens of national and international awards. These graduates are sought after by high tech companies for their combination of hands-on design experience and engineering science knowledge. Robert Henry Thurston would be proud.



3 D plot in brass of the torsional strength of copper alloy as a function of percent alloy composition; Copper, Tin, Lead. Data taken from the Thurston testing machine, circa 1885

## List of major Artifacts in the Robert H Thurston Collection at Cornell University

1. Autographic Testing Machine, US Patents 1874, 1880 of Robert H Thurston, Manufactured by Pratt and Whitney, Hartford Conn.
2. Lubrication Testing Machine, designed by Robert H Thurston
3. Working Model of Greene Steam Engine built by R H Thurston while at Brown University, c. 1855,
5. Working Model of Steam Engine used in teaching in the Sibley College, Cornell, c. 1900
6. Swiss and English Planimeters used to measure efficiency of steam engines, Sibley College, 1890 - 1900.
7. Pressure - Displacement indicators with straight-line kinematic mechanism used to measure efficiency of steam engines in Laboratory of Sibley College, c. 1890-1900.
8. Mechanical Strain measuring instruments used in metals testing laboratory, Sibley College, c. 1900.
9. Bronze topographic plaque showing the effect of alloys of Copper, Lead and Zinc based on torsional strength tests with Thurston's autographic testing machine [1]
10. Schroeder, German-made kinematic models of steam engine valve control mechanisms for steam engines, c. 1885.
12. Souvenir artifacts given to Professor R. H. Thurston as Mechanical Engineer for the Thurston-Gardener Company, Providence, R.I., Makers of Steam Engines, c. 1885.
13. Bas Relief Bronze Portrait of Robert H Thurston by artist Herman Atkins McNeil, 1910.
14. Personal books of Robert H Thurston [Thurston Bookplates]
  - a) *Report on Machinery and Manufactures at the Vienna International Exhibition 1873 with an account of European Manufacturing Districts* by Robert H Thurston, Member of the Scientific Commission of the United States. Washington Printing Office 1875 [includes original photographs]
  - b) *Materials of Engineering in three Parts: Part I Non-Metallic Materials, Part II Iron and Steel, Part III Non-Ferrous Metals.* J Wiley & Sons., 1883
15. *Sibley Journal of Engineering*, Robert H Thurston founding editor 1885 - 1903, Many Editorials Cornell University Library Rare Books Collections
16. Personal letters and papers of Robert H Thurston.

## References and Bibliography

- American Society of Mechanical Engineers (1915). *A History of the American Society of Mechanical Engineers from 1880-1915*, New York: ASME.
- Bell, J. F. (1973). *The Experimental Foundations of Solid Mechanics*, in *Mechanics of Solids*, vol. 1, Editor C. Truesdell, Springer Verlag, Berlin. [beginning page 450]
- Bishop, M. (1962). *A History of Cornell*, Ithaca, N.Y.: Cornell University Press.
- Calvert, M.A. (1967). *The Mechanical Engineer in America, 1930-1910: Professional Cultures in Conflict*, Baltimore, Md.: Johns Hopkins. See Chapter 5, "School versus Shop: Cornell's Sibley College," pp. 87-106.
- Carnot, Sadi (1890). *Reflections on the Motive Power of Heat and on Machines Fitted to Develop this Power*, translated by Robert H. Thurston, New York: J. Wiley & Sons.
- Dowson, D. (1979). *A History of Tribology*, London: Longman.
- Durand, W.F. (1929). *Robert Henry Thurston, a Biography*, New York: American Society of Mechanical Engineers.
- Hewett, W. T. (1905). *Cornell University: A History*, New York: University Publishing Society. See v. 2, ch. 4, "Sibley College of Mechanical Engineering", pp 303-325.
- Hutton, F. R. (1903). "Robert Henry Thurston: A Memorial," *Transactions of the American Society of Mechanical Engineers*, 25 (1903-04): 1113-1120.
- Kimball, D.S. (1935). "The Story of Sibley College of Mechanical Engineering and The Mechanic Arts" *The Sibley J. of Engineering Cornell University*, 49:4 (April 1935): 65-67, 80-82
- Nienkamp, P. (2016). "Robert Henry Thurston: Professionalism and Engineering Education," *American Educational History Journal*, 43 (2016): 129-148.
- Obituary (1903). "Robert Henry Thurston," *Science*, n.s. v. 18 (Nov 13, 1903): 609-611.
- Perkins F.C. (1891). *Cornell University; Her General and Technical Courses*, Buffalo: Art Printing Works.
- Thurston, R.H. (1898). "Work of the Founders; The Early History of Sibley College" *Sibley Journal. of Engineering*, 12:6 (March 1898): 255-260.

- Thurston, R.H. (1875) *Vienna International Exhibition 1873, Report on Machinery and Manufactures with an Account of European Manufacturing Districts*, Washington: Government Printing Office.
- Thurston, R.H. (1873) "Torsional Resistance of Materials Determined by a New Apparatus, with Automatic Registry", *Journal of the Franklin Institute*, 95 (1873): 254-260.
- Thurston, R.H. (1883) *The Materials of Engineering, in Three Parts*, New York: J Wiley and Sons.
- Thurston, R H (1907) *A Treatise on Friction and Lost Work in Machinery and Millwork*, seventh ed., New York: John Wiley & Sons. Originally publ. 1885.
- Thurston, R. H. (1893). "Technical Education in the United States," *Transactions of the American Society of Mechanical Engineers*, 14 (1893): 855-1013.
- Zieren, G. (2013). Robert H. Thurston, modern engineering education, and its diffusion through land-grant universities. In R. Geiger & N. Sorber (Eds.), *The land-grant colleges and the reshaping of American Higher Education* (Perspectives on the History of Higher Education 30, pp. 195–214). New Brunswick: Transaction Press.

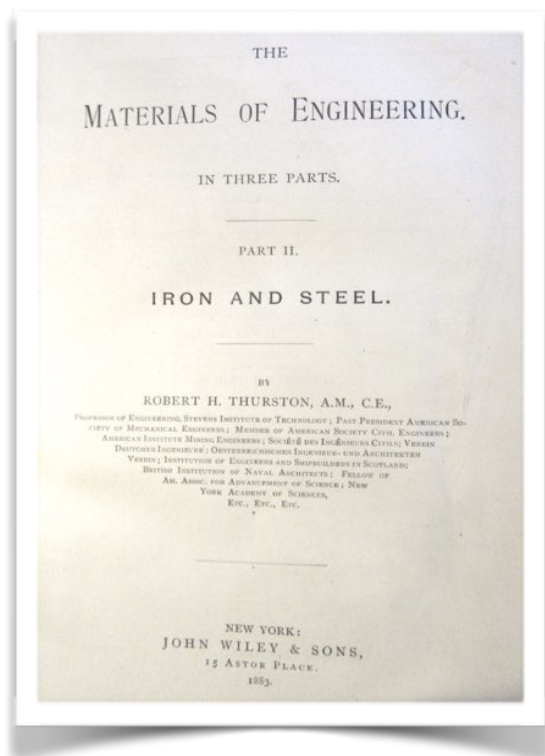

Front plate of Robert H Thurston's three volume work on the Materials of Engineering, published in 1883. This work describes the workings of his two major testing machines, the autographic torsion testing machine and the lubrication measurement machine.

## Where is the Cornell Thurston Collection Located?

The Thurston Collection is located on the Cornell University Campus in Ithaca, New York, on the Engineering Quadrangle, in Thurston Hall, and in Upson Hall, the home of the Sibley School of Mechanical and Aerospace Engineering.

For information about visiting the Thurston Collection, inquire with the Sibley School of Mechanical and Aerospace Engineering, Upson Hall, Cornell University, Ithaca, NY 14853; telephone (607)-255-3623; online at <http://www.mae.cornell.edu/>.



## The History and Heritage Program of ASME

Since the invention of the wheel, mechanical innovation has critically influenced the development of civilization and industry as well as public welfare, safety and comfort. Through its History and Heritage program, the American Society of Mechanical Engineers (ASME) encourages public understanding of mechanical engineering, fosters the preservation of this heritage and helps engineers become more involved in all aspects of history.

In 1971 ASME formed a History and Heritage Committee composed of mechanical engineers and historians of technology. This Committee is charged with examining, recording and acknowledging mechanical engineering achievements of particular significance. For further information, please visit <http://www.asme.org>

### LANDMARK DESIGNATIONS

There are many aspects of ASME's History and Heritage activities, one of which is the landmarks program. Since the History and Heritage Program began, 269 artifacts have been designated throughout the world as historic mechanical engineering landmarks, heritage collections or heritage sites. Each represents a progressive step in the evolution of mechanical engineering and its significance to society in general.

The Landmarks Program illuminates our technological heritage and encourages the preservation of historically important works. It provides an annotated roster for engineers, students, educators, historians and travelers. It also provides reminders of where we have been and where we are going along the divergent paths of discovery.

ASME helps the global engineering community develop solutions to real world challenges. ASME, founded in 1880, is a not-for-profit professional organization that enables collaboration, knowledge sharing and skill development across all engineering disciplines, while promoting the vital role of the engineer in society. ASME codes and standards, publications, conferences, continuing education and professional development programs provide a foundation for advancing technical knowledge and a safer world.

### ASME Officers

Said Jahanmir, President

Thomas Costabile, P.E., Executive Director/CEO

### ASME STAFF

Roger Torda, manager, Communications Projects & Initiatives

Wil Haywood, Communications Specialist

## **ASME History and Heritage Committee**

### *Members*

Herman H. Viegas, P.E.(Ret.) (Chair )  
Terry S. Reynolds, Ph.D. (Vice Chair)  
Lee S. Langston, Ph.D. (Secretary)  
Thomas H. Fehring, P.E. (Immediate Past Chair )  
Marco Ceccarelli, Ph.D.  
Richard I. Pawliger, P.E. (Ret.)  
Robert T. Simmons, P.E.

### *Corresponding Members*

John K. Brown, Ph.D.  
Scott Davidson, P.E. (Ret.)  
Francis C. Moon, Ph.D.  
Martin C. Ross, CDR USN  
Virginia Ross, Ph.D.  
Steven Walton, Ph.D.  
Robert O. Woods, P.E. (Ret.)

### *Emeritus Members*

J. Lawrence Lee, P.E. (Past Chair)  
Robert M. Vogel



## **ASME Student Chapter Cornell University**

Bhavi Jagatia, President  
Jordan Gurian, Vice President  
Shivanie Rambaran, Secretary  
Christopher Chan, Corporate Relations Lead  
Julia Radzio and Austin Gao, Public Relations Leads  
Ilayda Samilgil, Outreach Lead  
Akshay Kadhiresan, AIAA Liaison  
Elizabeth M. Fisher PhD, Associate Director of the Sibley School, Faculty Advisor

## **Thurston Display Committee**

Project coordinator, Professor Elizabeth M. Fisher  
Student ASME Chapter participants: Priscilla Chang, Ayinde Crear, Stanley Lok, and Kelly Waldvogel  
Text and Photos: Professor Emeritus Francis C. Moon  
Facilities coordinator Matt Steel, College financial coordinator: Thomas King  
Administrative support: Patti Wojcik  
Editing and Content Assistance: Terry S. Reynolds, Thomas H. Fehring, John Booker, Elizabeth M. Fisher



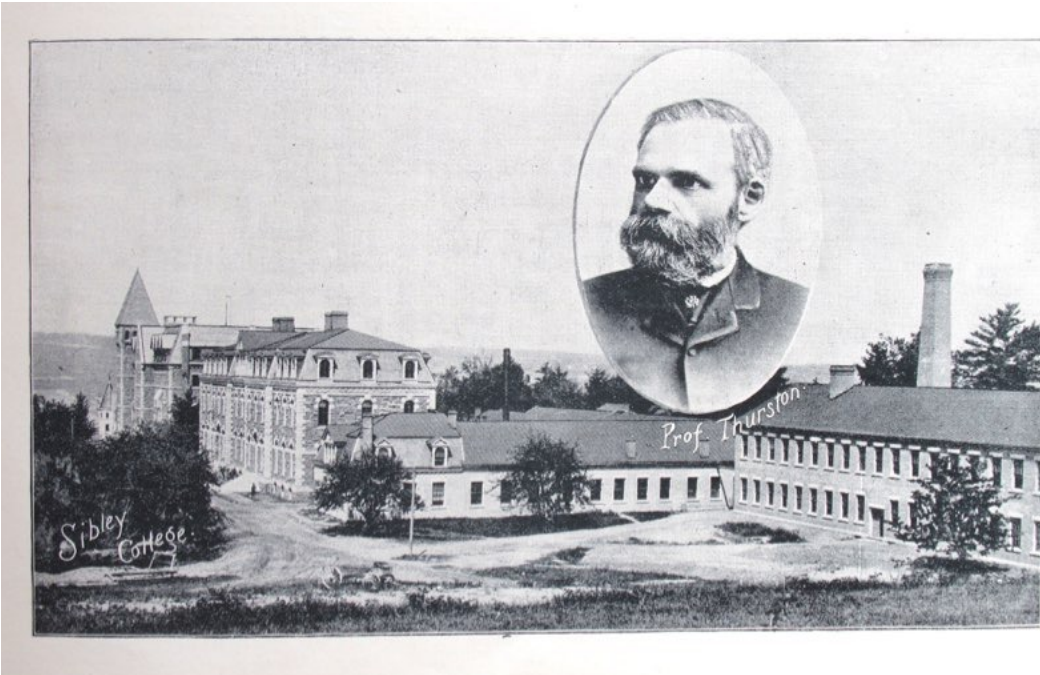

Sibley College of Mechanical Engineering and Mechanic Arts circa 1890.  
Insert Photo: Director Robert H Thurston



Renovated Upson Hall: Home of the Sibley School of Mechanical and Aerospace Engineering, Cornell University.



CAD drawing of the autographic recording mechanism of the Thurston Torsional Testing Machine, circa 1880. The pendulum arm and rectangular specimen grip is shown as the vertical element. The torsional load vs angular twist is recorded on the left hand cylinder.  
[CAD drawing by Priscilla Chang, BSME'21]

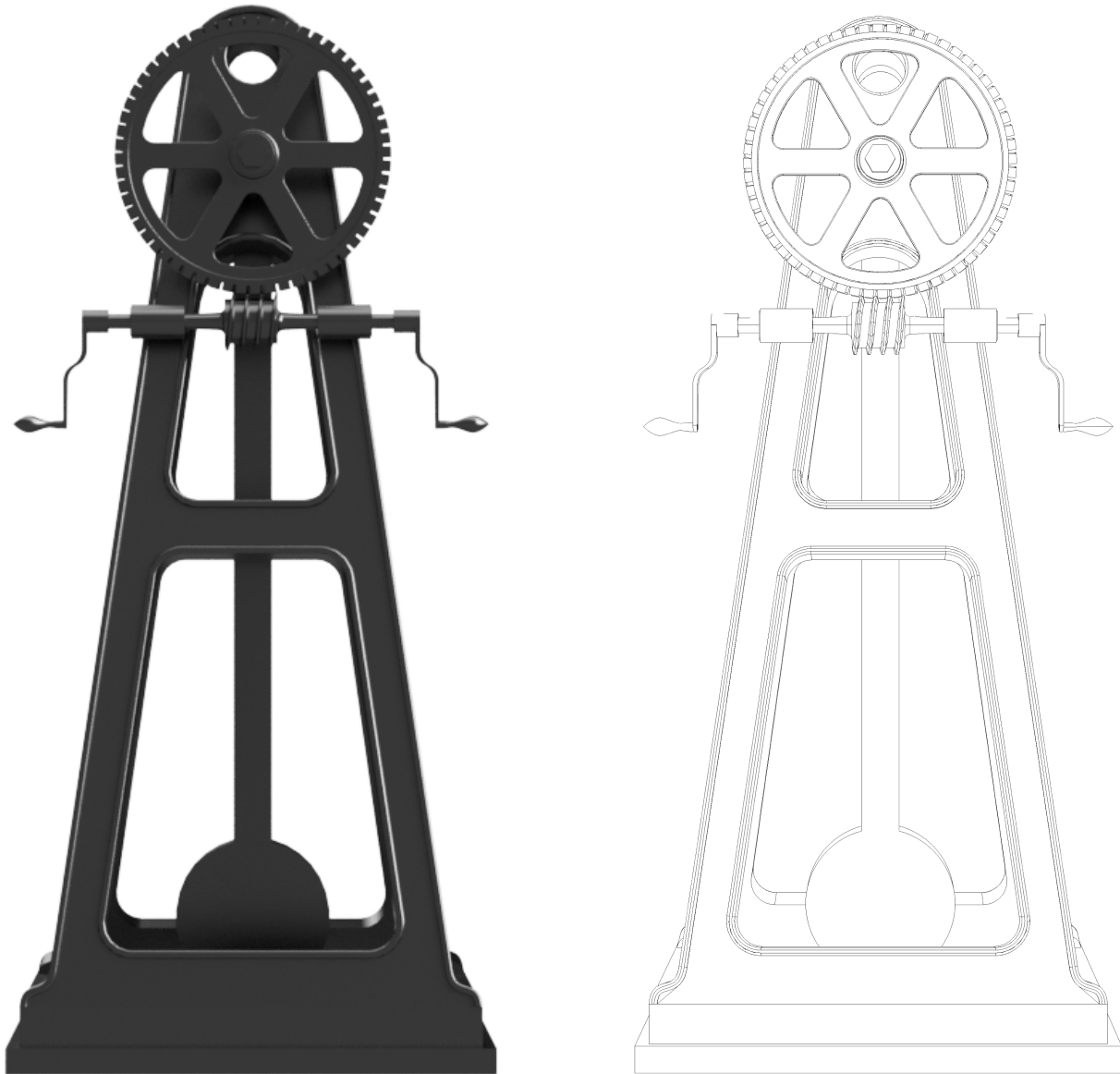

CAD drawings of Thurston Torsional Testing Machine showing the worm gear that turns the large gear and pendulum actuator that places a torque on the cylindrical test specimen (not shown).  
[Drawing by Ayinde Crear BSME'18, MENG'19]

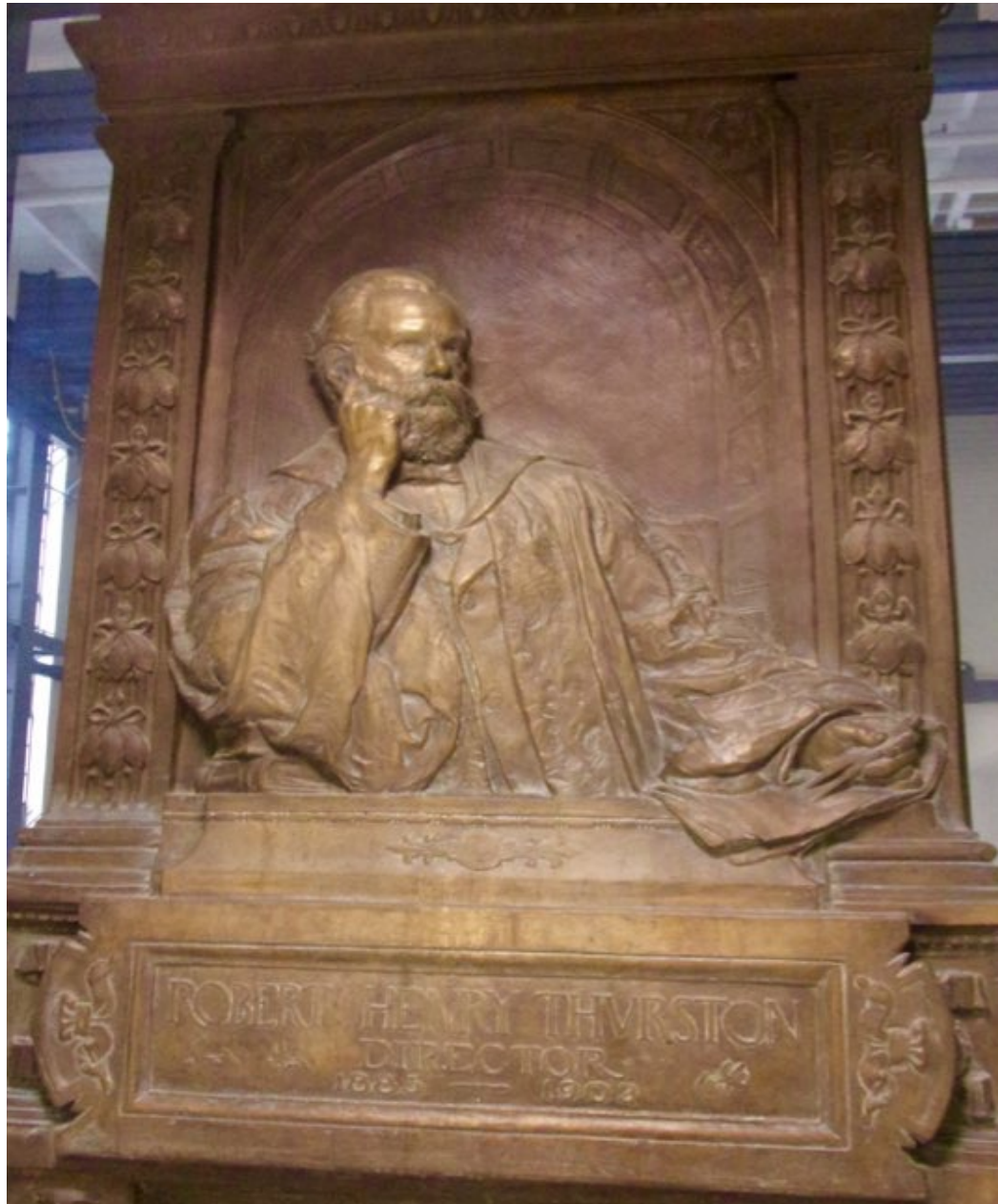

Bas-relief sculpture of Robert H Thurston, Director of Sibley College of Mechanical Engineering 1885-1903. The sculpture was created by Hermon Atkins MacNeil, who also did the Ezra Cornell sculpture on campus. MacNeil was hired by Thurston as an art instructor in the Sibley College.  
On display in Thurston Hall, Cornell University.